

ISOSCAN® PGH471/PGH473

Locating current injector for existing installations
with an integrated insulation monitoring device

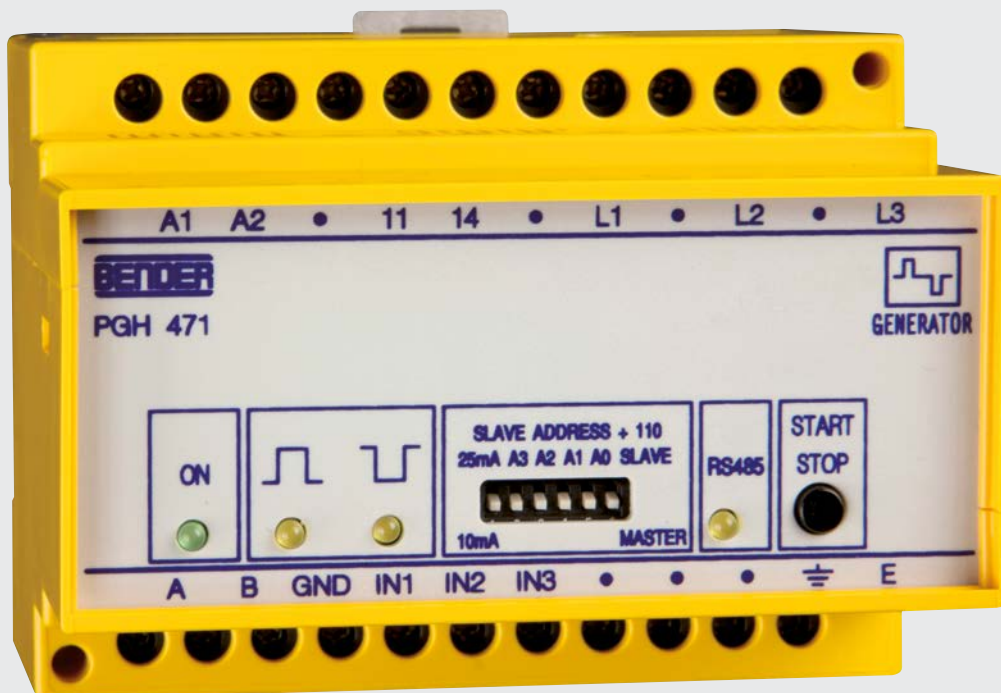

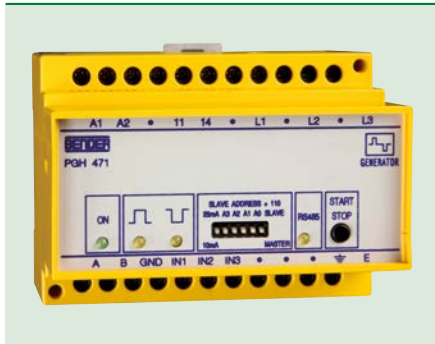

ISOSCAN® PGH471/PGH473

Device features

- Locating current:
 - PGH471: max. 25/10 mA;
 - PGH473: max. 2.5/1 mA
- Power On LED
- Alarm LED RS-485 active
- Two alarm LEDs for positive and negative clock signals of the locating current
- Alarm relay with one voltage-free N/O contact to signal that insulation fault location is being carried out
- Start/stop button to activate resp. deactivate insulation fault location

Approvals

PGH471:



Product description

The locating current injector PGH47... generates a locating current signal for insulation fault location. The variants differ in the value of the maximum permissible locating current. It is intended to be used in systems incorporating an insulation monitoring device.

Application

Locating current injector for insulation fault location systems

- PGH471: IT main circuits
- PGH473: IT control circuits

Function

The PGH47... locating current injector generates a test current signal which depends on the existing system voltage. Insulation fault location can be started either for one pass or continuously depending on the input chosen. With the test current activated, the alarm LEDs indicate the positive or negative test cycle in each case.

Standards

The ISOSCAN® PGH47... series complies with the requirements of the device standards: DIN EN 61557-8 (VDE 0413-8), EN 61557-8, IEC 61557-8, IEC 61326-2-4, DIN EN 60664-1 (VDE 0110-1), DIN EN 60664-3, DIN EN 61557-9, VDE 0413-9, IEC 61557-9, ASTM F1669M-96 (2007), ASTM F1207M-96 (2007)

Locating current injector PGH471/PGH473 in the EDS46... system

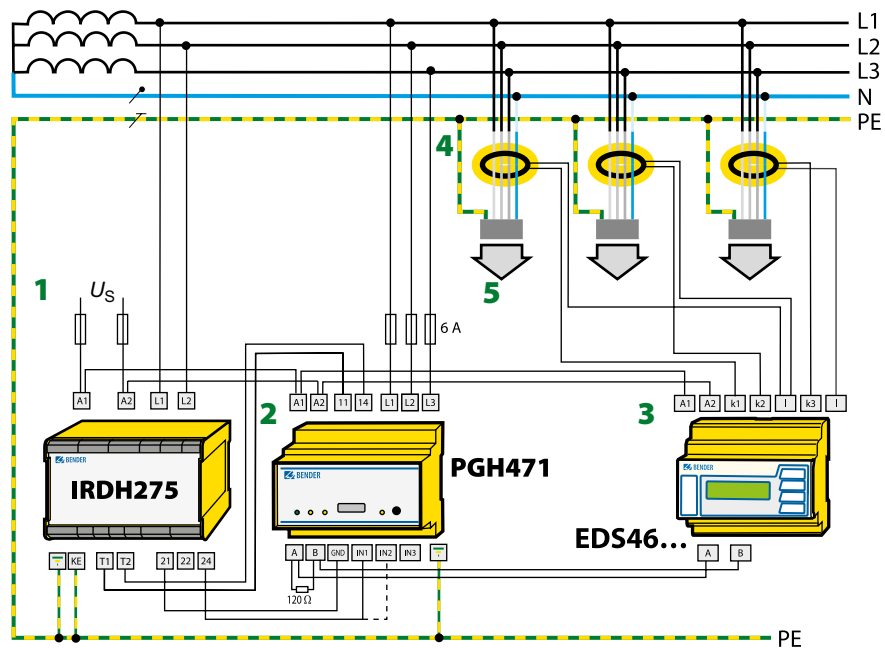

- | | |
|---------------------------------------|------------------------------------|
| 1 - ISOMETER® IRDH275 | 4 - Measuring current transformers |
| 2 - Locating current injector PGH471 | 5 - Outgoing circuits to the loads |
| 3 - Insulation fault locator EDS46... | |

Note: Only permanently installed equipment providing at least overvoltage category II (300 V) may be connected to the outputs.

Wiring diagram

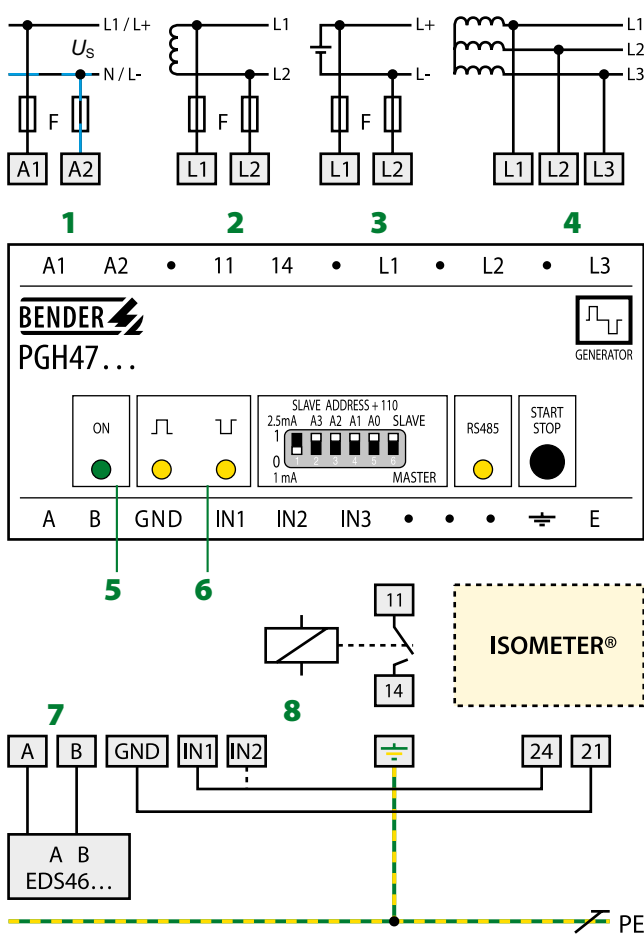

- 1 - U_s see nameplate, 6 A fuse recommended.
Supply voltage U_s in the IT system requires two fuses.
- 2 - IT system AC "L1, L2"
- 3 - IT system DC "L1, L2"
- 4 - IT system 3AC "L1, L2, L3"
- 5 - Power On LED "ON"
- 6 - LEDs clock pulse
- 7 - Connection BMS bus
- 8 - Alarm relay

Insulation coordination acc. to IEC 60664-1

Rated insulation voltage	AC 500 V
Rated impulse withstand voltage/pollution degree	4 kV/3

Voltage ranges

Nominal system voltage U_n PGH473	AC, 3(N)AC 20...265 V/DC 20...308 V/45...400 Hz
Nominal system voltage U_n PGH471	AC, 3(N)AC 20...575 V/DC 20...500 V/45...400 Hz
Supply voltage U_s	see ordering information
Operating range of U_s	0.85...1.15 x U_s
Power consumption	≤ 3 VA

Measuring circuit

Locating current	PGH473: 2.5 mA/1 mA; PGH471: 25 mA/10 mA
Clock pulse/break	2/4 s

Switching elements

Switching elements	1 N/O contact
Rated contact voltage	AC 250 V/DC 300 V
Making capacity	AC/DC 5 A
Breaking capacity	2 A, AC 230 V, cos phi = 0.4 - 0.2 A, DC 220 V, L/R = 0.04 s

Environment

Shock resistance IEC 60068-2-27 (device in operation)	15 g/10 ms
Bumping IEC 60068-2-29 (transport)	40 g/6 ms
Vibration resistance IEC 60068-2-6 (device in operation)	1 g/10...150 Hz
Vibration resistance IEC 60068-2-6 (transport)	2 g/10...150 Hz
Ambient temperature (during operation)	-10...+55 °C
Ambient temperature (during storage)	-40...+70 °C
Climatic class acc. to DIN IEC 60721-3-3	3K5

Connection

Connection type	modular terminals
Connection properties rigid/flexible	0.2...4 mm ² /0.2...2.5 mm ²

Other

Operating mode	continuous operation
Mounting	any position
Degree of protection, internal components (DIN EN 60529)	IP30
Degree of protection, terminals (DIN EN 60529)	IP20
Screw mounting	2 x M4
DIN rail mounting acc. to	IEC 60715
Flammability class	UL94 V-0
Documentation number	D00382
Weight	≤ 350 g

Ordering information

Locating current	BMS bus address range	Supply voltage U_S		Type	Art. No.
		DC	AC		
25/10 mA	111...119	–	230 V	PGH471	B95018004
		–	90...132 V ¹⁾	PGH471-13	B95018005
		10.5...80 V ¹⁾	–	PGH471-21	B95018006
		77...286 V ¹⁾	–	PGH471-23	B95018007
2.5/1 mA	121...150	–	230 V	PGH471E	B95018008
		–	230 V	PGH473	B95018009
	111...119	–	230 V	PGH473-13	B95018010
		10.5...80 V ¹⁾	–	PGH473-21	B95018011
	121...150	–	230 V	PGH473E	B95018015
		10.5...80 V ¹⁾	42...460 Hz	PGH473E-21	B95018016

¹⁾ Absolut values

Dimension diagram X470

Dimensions in mm

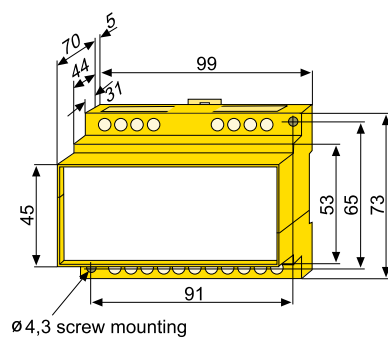

Bender GmbH & Co. KG

P.O. Box 1161 • 35301 Grünberg • Germany
 Londorfer Strasse 65 • 35305 Grünberg • Germany
 Tel.: +49 6401 807-0 • Fax: +49 6401 807-259
 E-Mail: info@bender.de • www.bender.de



BENDER Group