

# LINETRAXX® MRC410R

Single-channel AC and pulsed DC sensitive  
modular residual current device for AC systems





### Device features

- AC and pulse current sensitive residual current monitoring module for MRCD applications according to **IEC 60947-2 Annex M, Type A**
- Root mean square measurement (RMS)
- Residual operating current: 10 mA...30 A (42...70 Hz)
- Prewarning: 50...100 % of residual operating current
- Supply voltage DC 24 V , optional AC/DC 100...240 V (MRCD410R-2 only)
- LED-strip measured value display
- Adjustable response delay
- Alarm relay (designed as changeover contact)
- Non-fail-safe current/fail-safe current principle and fault memory behaviour selectable
- RS-485 with Modbus RTU
- Continuous CT-connection monitoring
- NFC interface for device parameter setting with the device energised or de-energised

### Intended Use

Modular residual current devices of type MRCD410R are designed for AC and pulsed DC residual and fault current measurement in earthed TN and TT networks. The devices can be used as an additional protective measure for the following protection goals, among others:

- Protection against indirect contact (DIN VDE 0100-410, IEC60364-4-41)
- Protection against thermal effects (DIN VDE 0100-420, IEC60364-4-42)
- System protection (DIN VDE 0100-430, IEC60364-4-43)

According to IEC 60364-5-53 and DIN VDE 0100-530, it is intended for use in earthed power supplies (TN and TT systems).

Please note that the standards mentioned may contain further requirements for use.

A modular fault current device according to product standard IEC60947-2 Annex M is completed by a measuring current transformer designed for this purpose and a circuit breaker with undervoltage release (device combination).



### ADVICE

*According to the product standard IEC60947-2 Annex M.7.1, it must only be possible to adjust the response value by means of an intentional action. This requires a cover that can be sealed.*

### The supplied sealing cover must be installed!

Suitable measuring current transformers are listed in the technical data. The switching time of the circuit breaker with undervoltage release incl. tripping device under load must not exceed 20 ms.

The requirements of the system and operating conditions on site and the application must be taken into account by selecting a suitable device combination and individual parameterisation. Furthermore, the notes, instructions and specifications in this manual must be observed and implemented.

The devices are intended for operation in control cabinets or similarly protected environments.

For intended operation, observe the specifications in this manual. Any other use than that described in this manual is regarded as improper.

**Wiring diagram**

**Control via undervoltage release (Fail-safe mode)**

**i** To comply with IEC 60947-2 Annex M, the MRCD410R must be operated in connection with a circuit breaker with undervoltage release or operating current release in fail-safe relay mode. The circuit breaker must comply with the IEC 60947-2 standard and be capable of switching off in less than 20 ms.

We recommend operating the signalling relay K in the **Fail-safe** mode. This allows the failure of the supply voltage and the failure of the internal power supply to be detected and reported.

The following settings need to be configured:

Modbus register	Parameter	Setting	Factory setting
32101	Relay mode	Fail-safe	Fail-safe
32200	Start with Alarm	Enabled	Enabled

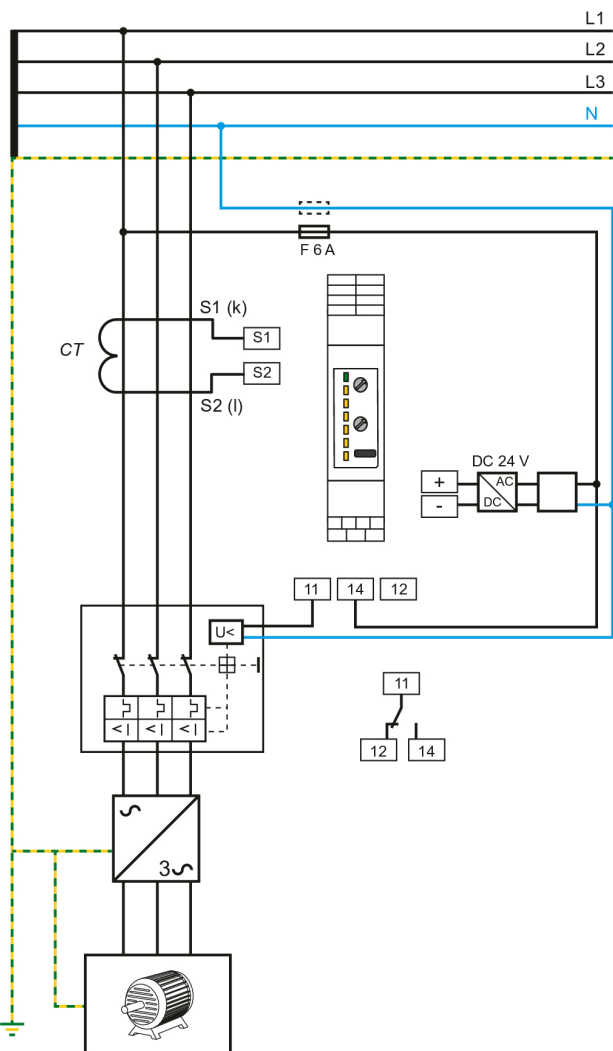

A MRCD410R-2 can alternatively be connected via terminals A1/A2 with AC/DC 100...240 V.

**ADVICE**  
 The supply voltage of the device must always be taken **before** the circuit breaker.

Wiring diagram with undervoltage release

**Control via shunt release ( Non-fail-safe mode)**

For economic installation reasons, the relay K can be operated in **Non-fail-safe** mode. Due to this relay mode, it is important to minimise risk by ensuring that the test intervals are carried out at shorter intervals based on a risk assessment.

In general, when applying the **Non-fail-safe mode** in the context of risk assessment, a concept must be developed for dealing with an interruption in the supply voltage to the MRCD410R.

The following settings need to be configured:

Modbus register	Parameter	Setting	Factory setting	
32101	Relay mode	Non-fail-safe	Fail-safe	<b>ADVICE</b> Manual adjustment required!
32200	Start with Alarm	Disabled	Enabled	<b>ADVICE</b> Manual adjustment required!

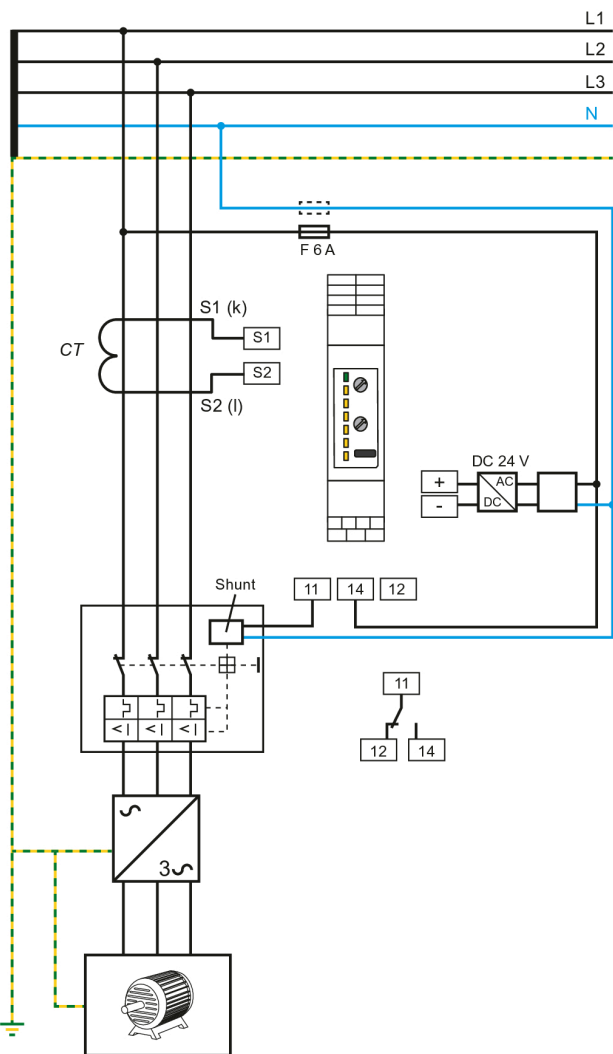

Wiring diagram with shunt release

A MRCD410R-2 can alternatively be connected via terminals A1/A2 with AC 100...240 V.

**ADVICE**  
The supply voltage of the device must always be taken **before** the circuit breaker.

Connections overview

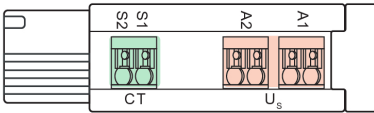
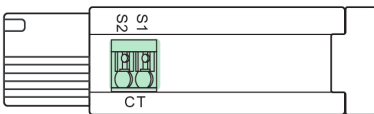
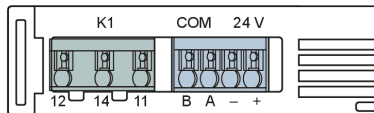
		Terminal	Connection
Top		A1, A2	Supply voltage $U_s$
		S1, S2	Measuring current transformer
Bottom		+	DC 24 V
		-	
		A	RS-485 A - Modbus RTU
		B	RS-485 B - Modbus RTU
		11, 14, 12	Alarm relay K1

NFC interface



The NFC interface can be used to transmit a previously configured device parameter setting directly to the device.



*This function is available only via the Bender Connect app. You can find this app in the App-stores for iOS and Android.*



In the Bender Connect app the device first needs to be made known. Then the device-specific setting options are shown so that they can be configured. When the data is transferred, feedback is given whether the parameter configuration has been successful.

Parameter settings can be transmitted to the device via the Bender Connect app by holding the mobile phone close to the device.

To a **de-energised** device, a parameter setting can be transferred via the Bender Connect app. This setting is then activated automatically when the device is connected to the current supply.

When a device is **plugged in**, too, parameters can be configured via the Bender Connect App. To this end, the NFC interface first needs to be activated in the device.

The NFC interface is activated via the T/R button at the front of the device or via the Modbus interface.

Dimension diagrams

Dimensions in mm

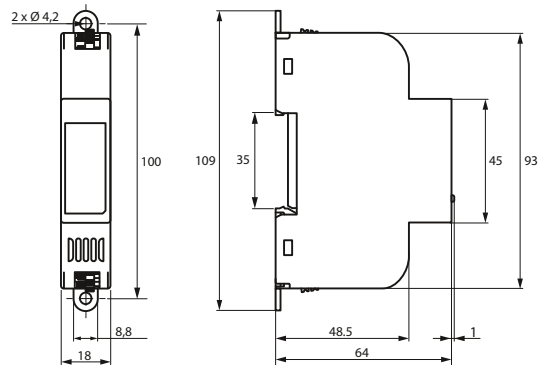

The NFC antenna is located at the front on the righthand side of the MRCD410R.

## Technical data

()\* = Factory setting

### Insulation coordination (IEC 60664-1/ IEC 60664-3)

#### MRCD410R-24

##### Definitions

Measuring & control circuit (IC1)	S1, S2, +, -, A, B
Output circuit (IC2)	11, 12, 14
Rated voltage	250 V
Overvoltage category	III
Operating altitude	≤ 2000 m AMSL
Rated impulse voltage	
IC1/IC2	4 kV
Rated insulation voltage	
IC1/IC2	250 V
Pollution degree	2
Protective separation (reinforced insulation) between	
IC1/IC2	300 V
Voltage test (routine test) acc. to IEC 61010-1	
IC1/IC2	AC 2.2 kV

#### MRCD410R-2

##### Definitions

Supply circuit (IC1)	A1, A2
Output circuit (IC2)	11, 12, 14
Measuring & control circuit (IC3)	S1, S2, +, -, A, B
Rated voltage	250 V
Overvoltage category	III
Operating altitude	≤ 2000 m AMSL
Rated impulse voltage	
IC1/(IC2-3)	4 kV
IC2/IC3	4 kV
Rated insulation voltage	
IC1/(IC2-3)	250 V
IC2/IC3	250 V
Pollution degree	2
Protective separation (reinforced insulation) between	
IC1/(IC2-3)	300 V
IC2/IC3	300 V
Voltage test (routine test) acc. to IEC 61010-1	
IC1/(IC2-3)	AC 2.2 kV
IC2/IC3	AC 2.2 kV

### Supply voltage

#### MRCD410R-2, MRCD410R-24

Connection	+, -
Supply voltage $U_s$	DC 24 V
Tolerance of $U_s$	-30...+25 %
Power consumption	≤ 2 W
Inrush current (< 5 ms)	< 10 A

### Supply voltage

#### MRCD410R-2

Connection	A1, A2
Supply voltage $U_s$	AC/DC 100...240 V (47...63 Hz)
Tolerance of $U_s$	±15 %
Power consumption	≤ 2 W / ≤ 3.5 VA
Inrush current (< 2 ms)	< 1.8 A

### Measuring circuit

Burden (internal)	33 Ω
Frequency range	42...70 Hz
Measuring current transformer monitoring	On
Measuring range (peak)	2 mA...70 A
Measuring range rms	2 mA...50 A
Rated residual operating current	30 A
Response value main alarm $I_{\Delta n}^{1)}$	10 mA...30 A (30 mA)*
Prewarning <sup>1)</sup>	50...100 % $\times I_{\Delta n}$ (70 %)*
Operating uncertainty	±10 % (at 0.5...5 $\times I_{\Delta n}$ )
Relative response uncertainty	-20...0 %
Rated thermal short-term current	2.4 kA/1 s
Hysteresis <sup>1)</sup>	10...25 % (15 %)*
Fault-memory alarm messages	On/off (on)*

<sup>1)</sup> Can only be configured via RS-485

### Measuring current transformers

Connection	CT (S1, S2)
Measuring-current transformer series, type A <sup>1)</sup>	CTAC... series
CT connection monitoring	Yes
Rated voltage $U_n$	See technical data of the measuring current transformer
Rated surge current	6.0 kA/40 ms
Connecting cables	See technical data of the measuring current transformer
Cable lengths	
Single wire $\geq 0.75 \text{ mm}^2$	0...1 m
Single wire, twisted $\geq 0.75 \text{ mm}^2$	0...10 m
Shielded cable $\geq 0.75 \text{ mm}^2$	0...40 m

<sup>1)</sup> For a selection of suitable measuring current transformers, see chapter "Measuring current transformer connection" in the manual

## Time response

Start-up delay $t$	0...900 s (0 s)*
Response delay $t_{on}$	
$I_{\Delta n} \leq 30$ mA	0 s
$I_{\Delta n} > 30$ mA	0...10 s (0 s)*
Delay on release $t_{off}$	0...900 s (0 s)*
Operating time $t_{ae}$	
with $1 \times I_{\Delta n}$	$\leq 180$ ms
with $2 \times I_{\Delta n}$	$\leq 130$ ms
with $5 \times I_{\Delta n}$ ( $I_{\Delta n} \leq 25$ A)	$\leq 20$ ms
with $5 \times I_{\Delta n}$ ( $I_{\Delta n} > 25$ A)	$\leq 23$ ms
with $10 \times I_{\Delta n}$ ( $I_{\Delta n} \leq 25$ A)	$\leq 20$ ms
with $10 \times I_{\Delta n}$ ( $I_{\Delta n} > 25$ A)	$\leq 23$ ms
Response time $t_{an}$	$t_{an} = t_{ae} + t_{on}$
Recovery time $t_b$	$\leq 500$ ms
Response time for CT connection monitoring	$\leq 5$ s

## Operation

Display	Status LED incl. LED bar graph
Display range, measured value	25 / 50 / 75 / 100 %
Button T/R	Reset / test / NFC / address setting

## RS-485 interface

Connection	A, B
Protocol	Modbus RTU
Baud rate	Max. 115.2 kbits/s (19.2 kbits/s)*
Parity	even, no, odd (even)*
Stop bits	1/2/auto (auto)*
Cable length (at 9.6 kbits/s)	$\leq 1200$ m
Recommended lines, shield on one side connected to PE	
CAT6/CAT7	Min. AWG23
min. J-Y(St)Y 2 x 0.6 mm <sup>2</sup>	Twisted pair
Required terminating resistor	120 $\Omega$ (> 0.25 W)
Device address	1...247 (100 + last two digits of serial number)*

## NFC interface

Frequency	13.56 MHz
Transmitting power (modulating; in 0 m distance, e.g.) <sup>1</sup>	0 W

- <sup>1</sup>
- EMC influences may lead to communication interruptions at the NFC interface.
  - The device does not transmit any radio waves when used as intended.

## Switching elements

Relay	1 changeover contact
Connection	11, 12, 14
Operating principle	Fail-safe or Non-fail-safe (Fail-safe)*
Electrical endurance, number of cycles	10000

## Contact data acc. to IEC 60947-5-1

Utilisation category	AC-13 / AC-14 / DC-12 / DC-12 / DC-12
Rated operational voltage	230 V / 230 V / 24 V / 110 V / 220 V
Rated operational current	5 A / 3 A / 1 A / 0.2 A / 0.1 A
Minimum contact load	
Relay manufacturer's reference	10 mA/5 V DC
<i>(Refers to relays that have not been operated with high contact currents.)</i>	

## EMC/Environment

EMC	IEC 60947-2 Annex M
Operating temperature	-25...+55 °C
Transport	-40...+85 °C
Long-time storage	-40...+70 °C

## Classification of climatic conditions acc. to IEC 60721

Stationary use (IEC 60721-3-3)	3K22
Transport (IEC 60721-3-2)	2K11
Long-term storage (IEC 60721-3-1)	1K22

## Classification of mechanical conditions acc. to IEC 60721

Stationary use (IEC 60721-3-3)	3M11
Transport (IEC 60721-3-2)	2M4
Long-term storage (IEC 60721-3-1)	1M12

## Connection

Terminals	Push-In
Connection properties	
rigid	0.2...1.5 mm <sup>2</sup> (AWG 24...16)
flexible	0.2...1.5 mm <sup>2</sup> (AWG 24...16)
with ferrule with plastic sleeve	0.25...0.75 mm <sup>2</sup>
with ferrule without plastic sleeve	0.75...1.5 mm <sup>2</sup>
<i>(Use crimping pliers similar to CRIMPFOX 6 / Weidmüller PZ6/PZ6/5 only)</i>	
Stripping length	8 mm

## Other

Operating mode	Continuous operation
Mounting	Vertical
Degree of protection (DIN EN 60529)	
terminals	IP20
internal components	IP30
Enclosure material	Polycarbonate
DIN rail mounting acc. to	IEC 60715
Flammability class	UL94 V-0
Weight	
MRCD410R-24	$\leq 60$ g
MRCD410R-2	$\leq 70$ g

## Approvals

### Standards & certifications

The MRCD410R device has been developed in accordance with the following standards:

- IEC 60947-2 Annex M
- UL508



### Licences

For a list of the open-source software used see our [Homepage](#).

### Declaration regarding the radio system

#### *EU declaration of conformity*

Bender GmbH & Co. KG hereby declares that the device covered by the Radio Equipment Directive complies with Directive 2014/53/EU. The full text of the EU Declaration of Conformity is available at the following internet address:

[EU declaration of conformity MRCD410R](#)

Hereby, Bender GmbH & Co. KG declares that this radio equipment complies with Radio Equipment Regulations 2017 (S.I. 2017/1206). The full text of the UK declaration of conformity is available at the following internet address:

[UKCA-Declaration of Conformity MRCD410R](#)

## Ordering information

Type	Supply voltage $U_s$	Measuring current transformers that can be used	Art. No.
		Type A	
MRCD410R-24	DC 24 V	X	B74602020
MRCD410R-2	DC 24 V AC/DC 100...240 V	X	B74603020

Accessories	Art. No.
Sealable transparent cover (spare part)	B80609199



### Bender GmbH & Co. KG

Londorfer Straße 65  
35305 Grünberg  
Germany

Tel.: +49 6401 807-0  
info@bender.de  
www.bender.de



© Bender GmbH & Co. KG, Germany  
Subject to change!  
The specified standards take into account the edition valid until 05.2026 unless otherwise indicated.