

## Renewable energy

## Reliable and efficient use of the power of nature





# Solutions for electrical safety

## Electrical safety for efficient use of renewable energy

Making efficient and reliable use of natural energy resources, that is the system operator's aim, regardless of whether these are solar, wind, hydro or biogas systems. Bender offers proven, tried-and-tested and reliable solutions for

- early detection of possible electrical hazards
- guaranteed safety of persons and plants
- immediate recognition of critical operating statuses of electrical installations
- minimisation of failure risks and operational interruptions
- guaranteed high system availability by means of preventive intervention
- efficient system data management.

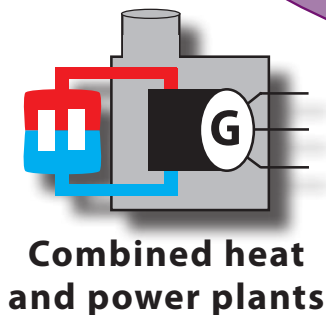
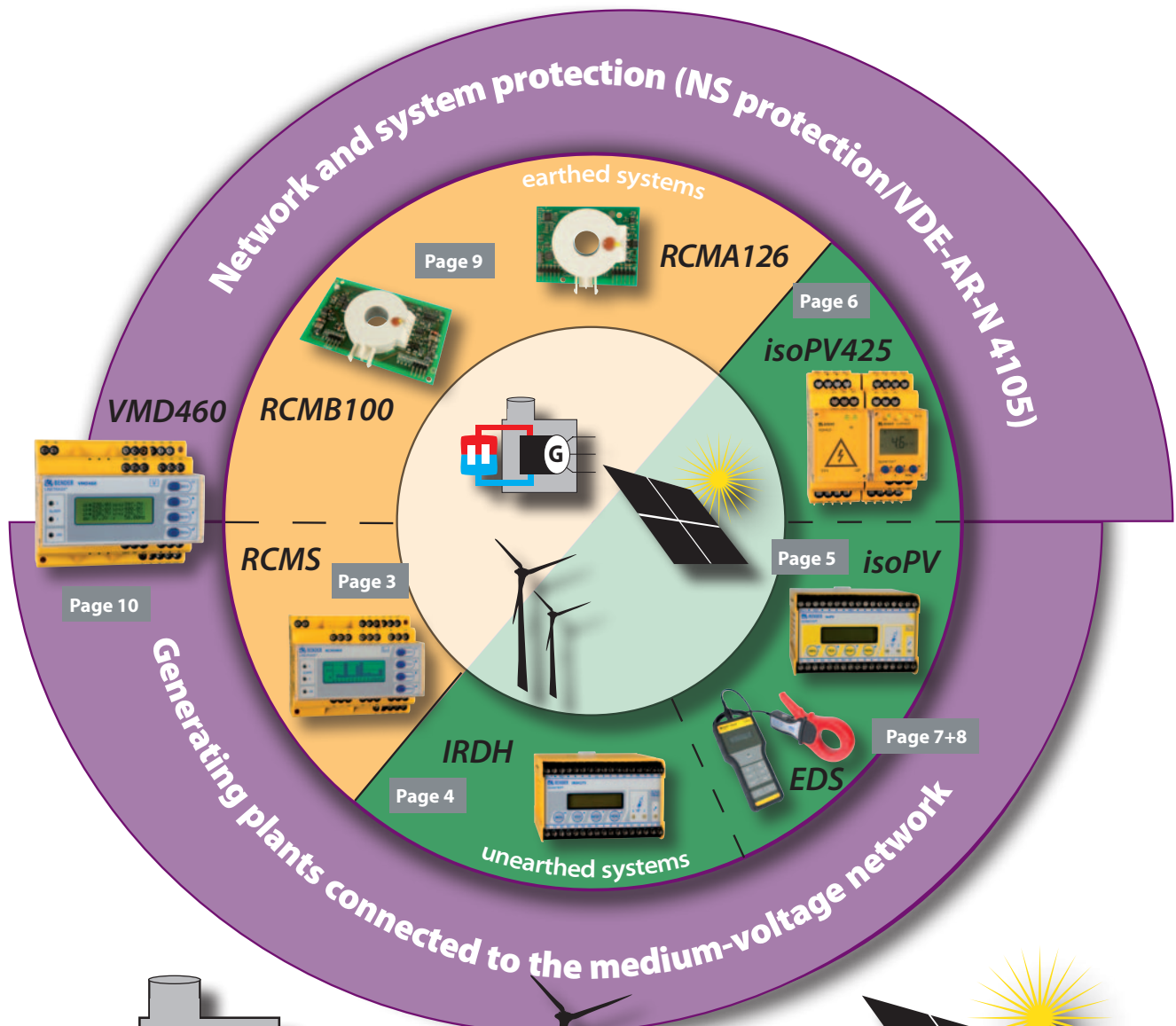

# High availability of wind energy plants

## Early detection instead of downtimes

If the issue is the high availability and reliability of wind energy plants, the operators have only one goal – to prevent any unexpected failure or malfunctions in day-to-day operation, as a failure means financial losses.

A crucial role is played here by the electrical safety. An unexpected insulation fault often means unexpected downtime or an increased risk of fire. Also unplanned service visits are expensive in terms of time and money.

### The most common cause for insulation faults resp. fault currents is defective insulation due to

- Physical damage to wires by
  - vibration
  - torsion
  - wide temperature range
- Too low insulation resistance by
  - moisture
  - gear oil and und hydraulic oil
  - dirt
- Lightning strokes

### Fault currents or insulation faults have serious consequences, e.g.:

- High costs due to operational interruptions
- Risk of fire at power dissipation  $> 60\text{ W}$
- Failure of safety-critical systems
- Unplanned maintenance measures
- Unexpected triggering of protective devices
- Hazards for maintenance personnel

### In earthed systems

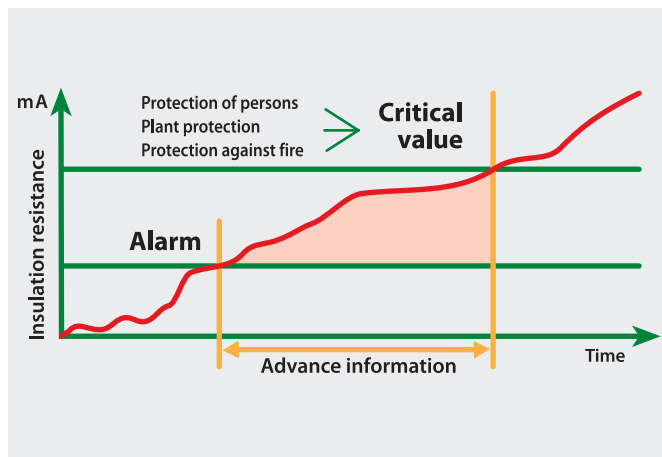

Obtain your edge of information with RCMs

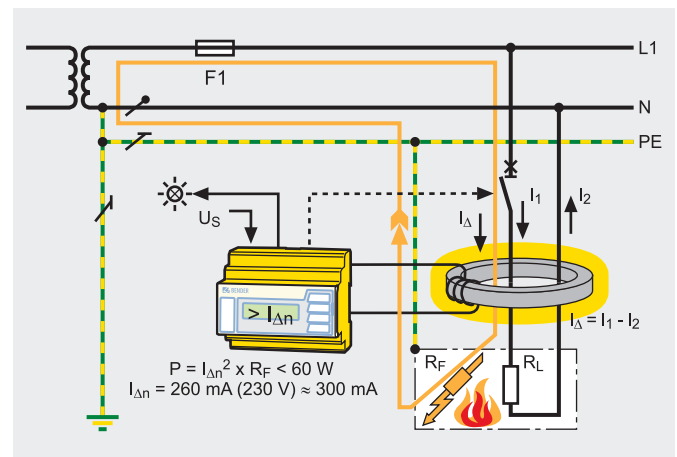

Risk of fire due to insulation fault ( $P > 60\text{ W}$ )

## Residual current monitoring device / system (RCM/RCMS) in practice – protection against unexpected shutdown and risk of fire

### What should you do?

- Permanently monitor the residual current on important components
- Install residual current monitoring devices / systems in addition to existing protective devices
- Keep the insulation resistance of the installation high by immediately localising and rectifying insulation faults

### Your benefits

- Increased availability of the installation
- Personnel, fire and installation safety
- Increased rate of return on the installation due to reduced downtimes
- No unexpected shutdown, fault currents in the mA range are detected at an early stage and signalled
- Service visits can be better planned



### In unearthed systems

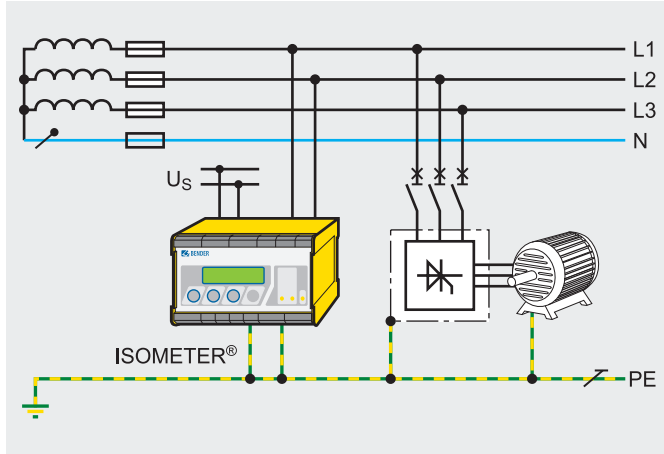

Insulation monitoring in main circuits

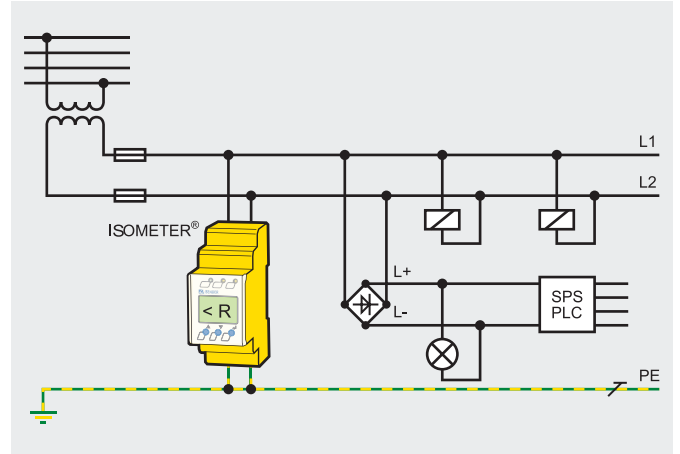

Insulation monitoring in auxiliary and control circuits

## Insulation monitoring devices (ISOMETER®) in practice – greater information advantage

Unearthed power supplies (IT systems) have an invaluable advantage in that a first fault will not cause a failure. As a result complex processes and the operation of the wind energy plants are not interrupted. Quite the contrary, IT systems can continue to operate under controlled conditions and faults can be rectified at an appropriate stage, without incurring the costs associated with failures.

IT systems differ from each other in terms of the voltage level, the natural insulation resistance, the amount of leakage capacitances and the voltage waveform (AC, DC, AC and DC components, etc.). The requirements on insulation monitoring result from these characteristics.

### What should you do?

- Select the IT system
- Use an appropriate insulation monitoring device (ISOMETER®)
- Permanently monitor the entire insulation resistance

### Your benefits

- Highest possible availability of the installation, as the first insulation fault does not result in shutdown
- Higher, more reliable earthing resistance
- Due to low fault currents, no risk of fire
- More flexibility during maintenance
- Improved electromagnetic compatibility
- decisive information advantage

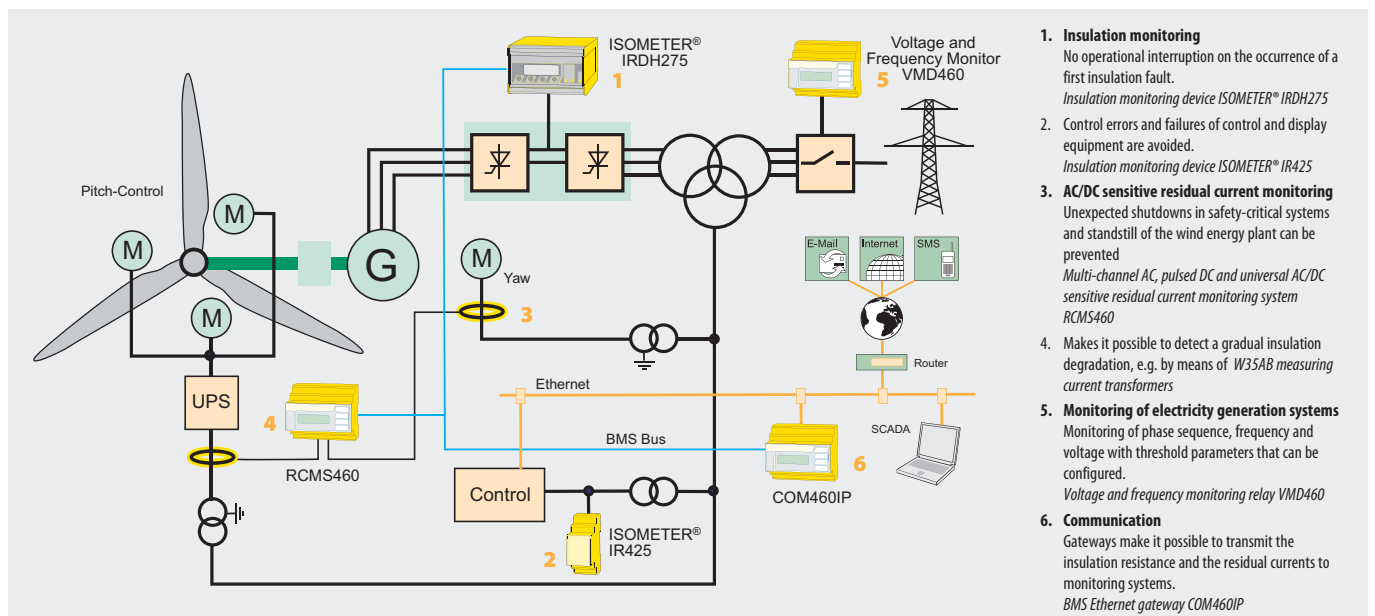

- 1. Insulation monitoring**  
No operational interruption on the occurrence of a first insulation fault.  
*Insulation monitoring device ISOMETER® IRDH275*
- 2. Control errors and failures of control and display equipment are avoided.**  
*Insulation monitoring device ISOMETER® IR425*
- 3. AC/DC sensitive residual current monitoring**  
Unexpected shutdowns in safety-critical systems and standstill of the wind energy plant can be prevented  
*Multi-channel AC, pulsed DC and universal AC/DC sensitive residual current monitoring system RCMS460*
- 4. Makes it possible to detect a gradual insulation degradation, e.g. by means of W35AB measuring current transformers**
- 5. Monitoring of electricity generation systems**  
Monitoring of phase sequence, frequency and voltage with threshold parameters that can be configured.  
*Voltage and frequency monitoring relay VMD460*
- 6. Communication**  
Gateways make it possible to transmit the insulation resistance and the residual currents to monitoring systems.  
*BMS Ethernet gateway COM460IP*

# High availability of large photovoltaic systems



ISOMETER® isoPV

## Why unearthed photovoltaic systems?

- No operational interruption on the occurrence of a first insulation fault
- Increased fire protection
- Early detection and signalling of developing insulation faults
- Enhanced personal safety
- The PV system is kept at a high level of availability
- Insulation fault location during operation of the photovoltaic system
- Costs for time and personnel can be drastically reduced
- Localising insulation faults all the way to the photovoltaic module
- Allows a distinction to be made between resistive and capacitive components

## Increased performance without additional effort

While during the planning of a photovoltaic system the implementation of the project with the lowest possible costs is in the foreground, during the operation of the completed system the focus is on the revenue. Failures are to be avoided at all costs. The investment costs for suitable insulation monitoring are already amortised on the occurrence of the first insulation fault.

Where, nevertheless, a TN system has been chosen in preference to the more reliable and stable IT system, in many industrial sectors this is due to the high investment costs associated with the required transformer. For photovoltaic plants in the MVA range, however, the galvanic isolation in form of a medium voltage transformer, that is required for the IT system, is already realised. An unearthed system with suitable monitoring according to DIN VDE 0100-410 is ideally suited for this purpose.

The device series is optimised for low insulation values and high system leakage capacitances in large-scale plants.

It is not without reason that the isoPV series Bender ISOMETER® was voted the Best Product of Contest at the international tradefair for the electrical and electronics industry ELECRAMA 2012. The isoPV monitors photovoltaics systems with outputs up to several MVA safely and reliably.

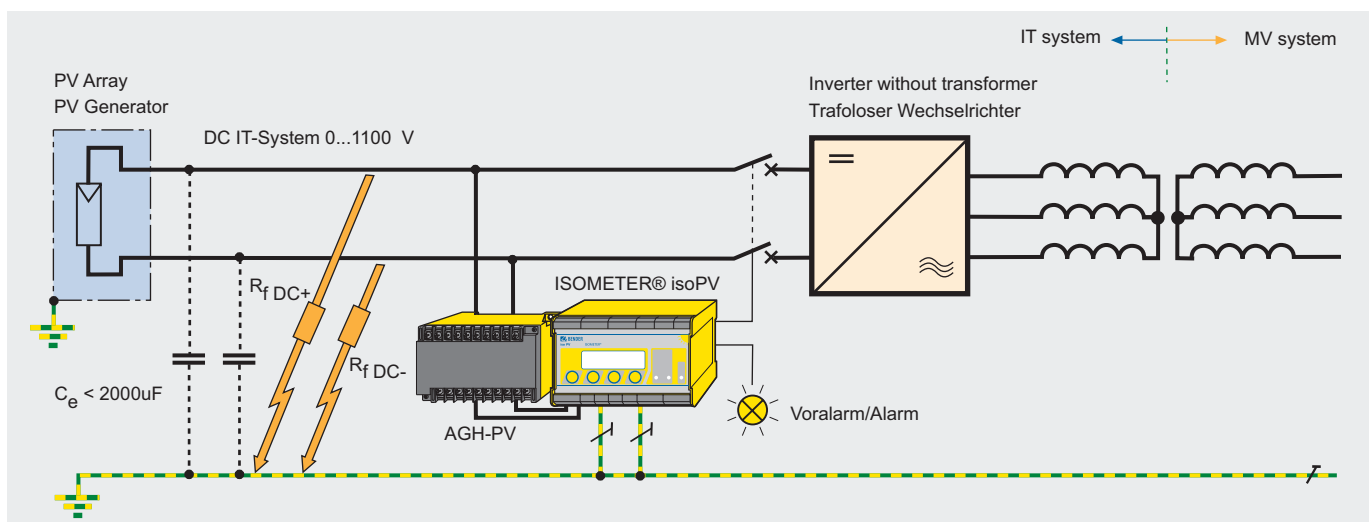
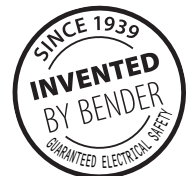

Typical design of an unearthed photovoltaic system in the MVA power range



# High availability of unearthed photovoltaic systems

## Photovoltaic inverters with galvanic isolation

For photovoltaic systems with galvanic separation in the inverter, an ISOMETER® of the middle price and performance category is the choice for monitoring the unearthed system (IT system) in compliance with DIN VDE 0100-410. Independently from any insulation measurement carried out by the inverter prior to connection, the entire photovoltaic array is permanently monitored by the ISOMETER® which satisfies the requirements of DIN VDE 0100-410 (IEC 60364-4-41).

The IEC 61557-8 requires that also symmetrical insulation faults are to be detected. Symmetrical faults are caused by moisture and dirt, for example – particularly in the case of photovoltaic systems these faults are more common. The isoPV485 uses the Bender AMP measurement method and also detects reliably insulation faults with a maximum leakage capacitance of up to 500 µF. The recommended size of installation therefore is max. 500 kW.

### ISOMETER® isoPV

- Precisely measure the insulation resistance using the patented measurement method
- Are perfectly tailored to the requirements of photovoltaic systems (presetting for PV systems)



Insulation monitoring device for unearthed AC/DC IT systems in small and medium-sized photovoltaic systems: isoPV425

### Your advantages

- No operational interruption on the occurrence of the first insulation fault
- High level of efficiency of the photovoltaic system through the whole service life
- Unexpected maintenance measures are avoided
- Optimised deployment of personnel and planning of time resources
- Insulation fault location during operation

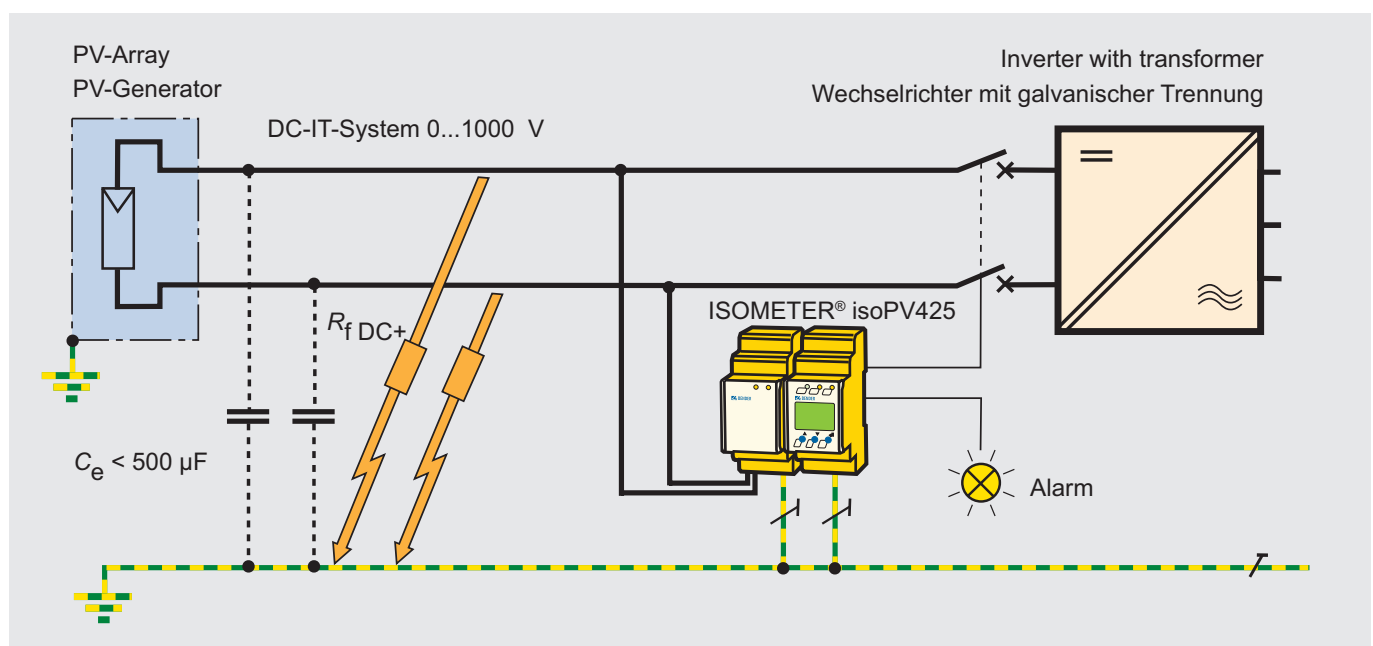

Typical design of an unearthed photovoltaic system in the range > 500 kVA

# Equipment for insulation fault location during operation

The insulation monitoring of an unearthed installation (IT system) in compliance with the requirements of DIN VDE 0100-410 can be realised with an ISOMETER®. Insulation faults are recognised and signalled reliably. The subsequent localisation of an insulation fault, however, can be an extremely time-consuming and costly affair– in particular in photovoltaic systems that are physically very large. This problem can be remedied with insulation fault location systems (IEC 61557-9), Bender's EDS systems.

## Portable solutions

With the portable insulation fault location system EDS3090 from Bender, insulation faults can be localised in a fast and uncomplicated way. For this purpose, a locating current injector (PGH) has to be connected to the photovoltaic system. It generates a specific pulsed locating current which is always limited to a maximum value. Using the mobile insulation fault locator EDS195P and a measuring clamp with the appropriate diameter, the location of the fault can be narrowed down to the string level. Using two measuring clamps makes it even possible to locate the damaged module. Localising insulation faults by means of the insulation fault location system not only is much easier and faster but can also be carried out during operation.

The portable insulation fault location system EDS3090PG in a compact case which weighs just 7 kg is especially suitable for maintenance work of different photovoltaic systems (e.g. service providers for technical management). Also for individual large-scale systems, the EDS3090PG will pay for itself within a relatively short period. The graphic on page 8 illustrates how to combine portable and permanently installed equipment for insulation fault location.



Portable equipment for insulation fault location EDS3090PG

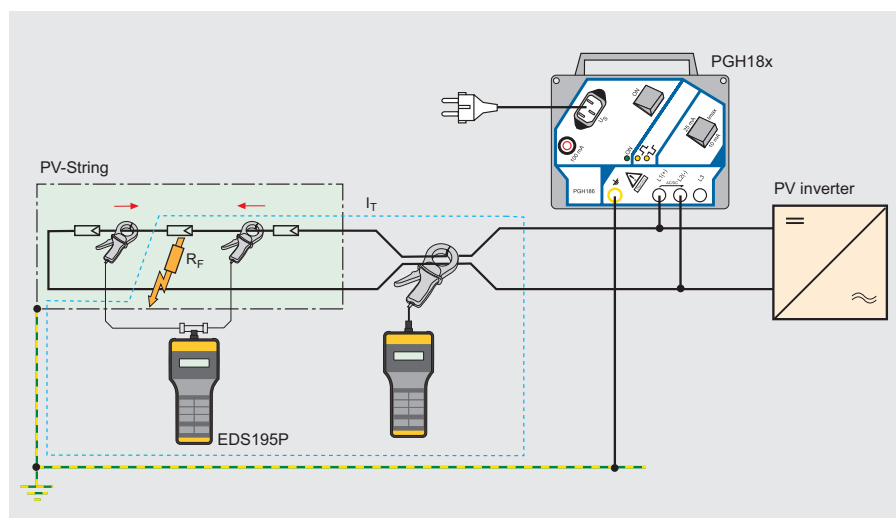

Principle of manual insulation fault location in a photovoltaic string



### Your advantages

- Precise fault location within a relatively short period
- Significantly lower outlays in terms of personnel and time
- Modular system concept for optimal adaptation to the electrical installation



# Equipment for insulation fault location during operation

## Solutions for the installation

Insulation fault location in expanded photovoltaic systems is a time-consuming and costly affair. Insulation faults in unearthed power supplies can be localised fast and reliably using the portable or permanently installed insulation fault location system EDS.



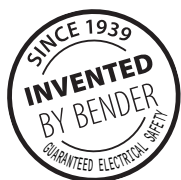

The EDS system will pay for itself within a relatively short period by drastically reduced maintenance costs and by avoiding unnecessary costs as a result of operational interruptions.



*EDS460-DG Insulation fault locator for automatic insulation fault location*

### Possible combinations

#### Locating current injectors PGH and insulation fault locators EDS

	Locating current injectors PGH	Insulation fault locators EDS
permanent	 PGH471	 EDS460 W20   EDS195P
mobile	 PGH18x	 EDS195P

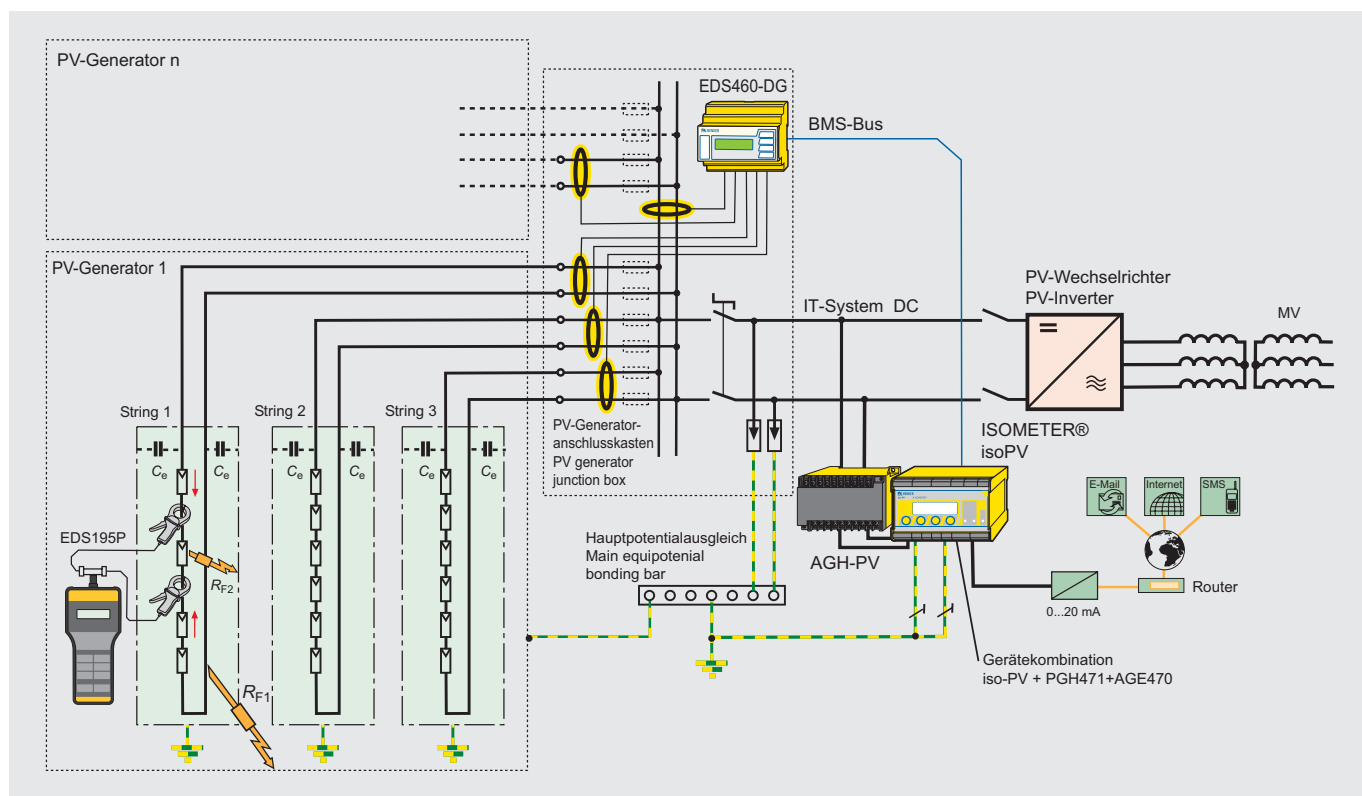

*Principle of a photovoltaic system with insulation monitoring and manual/automatic insulation fault location*





# RCMU solutions for the integration in inverters

## Normative requirement

On the DC side of photovoltaic systems the protective measure "double or reinforced installation" is preferably used (DIN VDE 0100-410). In this case, the solar modules are designed as protection class II equipment. Where this protective measure is used as a sole means of protection, appropriate monitoring of the installation concerned must be demonstrated. For this purpose, residual current monitoring unit (RCMU) acc. to DIN V VDE V 0126-1-1 and IEC 62109-2 are required for PV inverters without electrical separation.

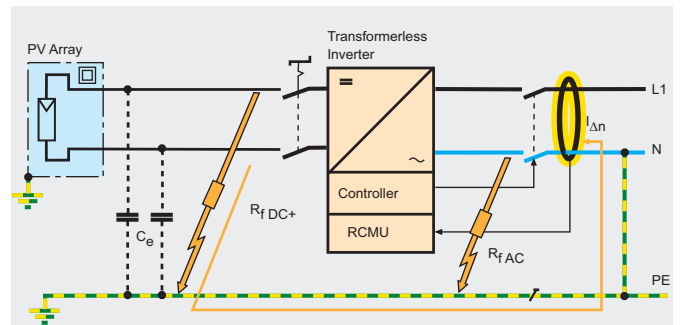

RCMU in PV inverters without electrical separation

## AC/DC sensitive RCM technology

The integrated RCM solutions from Bender ensure reliable and standard-compliant operation of inverters without electrical separation. Residual current monitoring is carried out using an internal AC/DC sensitive measuring current transformer. Optionally, the residual current is available as an output

voltage proportional to the residual current at the signal output or as a temporally integrated signal in accordance with the requirements of DIN V VDE V 0126-1-1 and IEC 62109-2. All variations are completely screened and are therefore insensitive to load currents.



RCM solutions by comparison	Type	
	RCMB100	RCMA126
Certifications	UL 1998 UL 508	UL 508
Primary nominal current $I_n$	50 A	50 A
Measuring range $I_{\Delta}$	0...100 mA	0...100 mA
Frequency range $f$	DC...500 Hz	DC...500 Hz
Ausgang/Output $V_{out}$	Analogue output DC 0..5 V open collector output (temporally integrated signal)	PWM signal $f = 8$ kHz (temporally integrated signal)
Supply voltage $U_s$	$\pm 12$ V $\pm 15$ V	15 V $\pm 5$ V 3.3 V
Dimensions W/D/H	94 x 58 x 17 mm	65 x 50 x 17 mm



## Safe connection to the grid

### VMD460 – Interface Protection System (decoupling protection) compliant with the standards for photovoltaic systems, CHPs, wind and hydroelectric power

The VMD460 provides external interface protection system that isolates the connection between the public grid and the power generation system by operating interface switches in case of limit infringements. If voltage and frequency measurements on the power generation system are outside the thresholds required in the standards, the power generation system is isolated from the public grid.

The VMD460 is multifunctional and can be used in many applications based on national or plant-specific requirements. The related parameters are saved in pre-set basic programs. The VMD460 combines safe function with a high degree of flexibility and straightforward configuration.

#### Device features

- Straightforward commissioning
- Pre-set response values for national standards and regulations
- Single fault safety
- Monitoring of the interface switches connected
- Islanding detection  $df/dt$  (ROCOF)
- RS-485 interface (data exchange and software update via BMS bus)
- Test function for the determination of the shutdown time
- History memory of last 300 events and faults with real-time clock-calendar time stamp
- Continuous monitoring of phase voltage and line conductor voltage
- Separate switching conditions after a threshold infringement
- Test button for the tripping circuit
- Language selection (German, English, Italian)
- Illuminated, multi-line graphic display
- Password protection for device settings



Interface protection system VMD460

#### Example applications

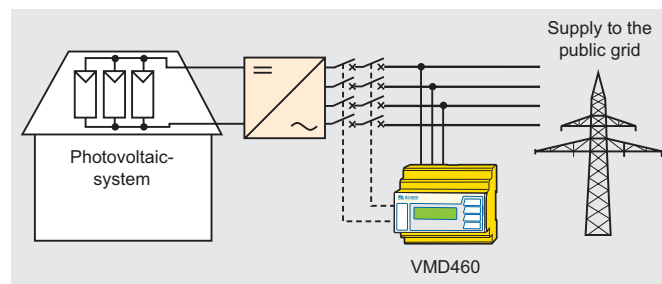

Schematic diagram of continuous voltage and frequency monitoring

- Automatic disconnection device between a power generation system and the public grid
- Application as per
  - CEI 0-21 (Italy, ...)
  - VDE-AR-N 4105 (Germany, Denmark, ...)
  - C10/11 (Belgium, ...)
  - G59/2 (United Kingdom, ...)
  - G83/2 (United Kingdom, ...)
  - DIN V VDE V 0126-1-1 (France, Greece, Ireland, Norway, ...)
  - BDEW regulations (medium voltage)



# Our first-class service ensures you achieve the maximum safety for your electrical systems

We would be delighted to see your project through from initial planning and design to modernisation.

Planning & concept	Selection of devices & project scheduling	Installation & commissioning	Operation & maintenance	Expansion & Modernisation
<p><b>From support to customised solutions</b></p> <ul style="list-style-type: none"> <li>• Detailed as-is analysis</li> <li>• Technical support for products and systems</li> <li>• Application assistance</li> <li>• Seminars, training and presentations</li> </ul>	<p><b>From the selection of the device to project scheduling</b></p> <ul style="list-style-type: none"> <li>• Selection of the appropriate components and systems</li> <li>• Working out a detailed solution</li> <li>• Assistance in tender invitations and project awarding</li> </ul>	<p><b>From installation to final inspection</b></p> <ul style="list-style-type: none"> <li>• Installation check</li> <li>• Parameter settings and adjustments</li> <li>• Test run and final inspection</li> <li>• Operator instruction/training</li> </ul>	<p><b>From maintenance to repair</b></p> <ul style="list-style-type: none"> <li>• Repair/ troubleshooting</li> <li>• Maintenance, repairs, spare parts</li> <li>• Maintenance/repair works</li> </ul>	<p><b>From expansion to modernisation</b></p> <ul style="list-style-type: none"> <li>• Technical advice on the improvement and modernisation</li> <li>• Planning and implementation of retrofitting</li> <li>• Optimisation of installations and installation sections</li> </ul>

## Solarbox 4105

– Ready-to-connect distribution box for central network and system protection with redundant switching device

With the Solarbox 4105, our partner **bendersystembau** offers you a complete solution. The ready-to-connect AC distribution box operates as central NS protection between a power generation system operated in parallel with the network and the public low-voltage grid.



Sample configuration

**bendersystembau** will develop and realise project and customer-specific solutions for applications exceeding the standard requirements.

**Just talk to us about it!**

# Bender agencies worldwide

A close network of sales offices and agencies home and abroad is in constant dialogue with the customer. This guarantees competent advice, reliable deliveries and perfect service.



## **Bender GmbH & Co. KG**

P.O.Box 1161 • 35301 Grünberg • Germany

Londorfer Straße 65 • 35305 Grünberg • Germany

Tel.: +49 6401 807-0 • Fax: +49 6401 807-259

E mail: [info@bender-de.com](mailto:info@bender-de.com) • [www.bender-de.com](http://www.bender-de.com)

**BENDERGroup**